

Toilet & Privacy Partitions Assembly Instructions

Make certain you are familiar with all hardware packs, their contents and use before proceeding. Due to the custom job nature of privacy partitions, the following step-by-step instructions are intended to be used as a guideline. Certain types of installations and unique site conditions may not be covered specifically.

To insure an excellent, attractive installation make sure you have thought the installation through. Familiarize yourself with all of the components, and check the shop drawing before cutting and drilling. Wall structures should include proper blocking for mounting brackets and fasteners.

LAYOUT

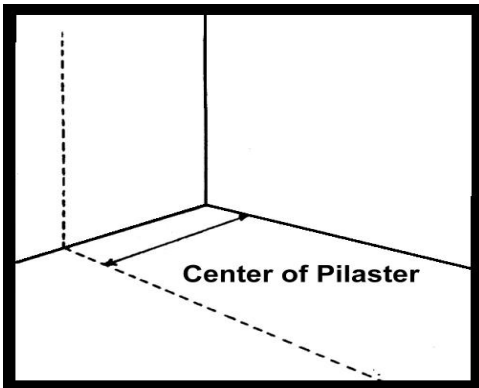

(fig.1)

Determine the depth of the toilet compartment installation. Find the pilaster centerline from the shop drawing. Measure from the rear wall to front pilaster depth and reduce half the thickness of your pilaster which will be chalk lines as illustrated. These lines will be the center line for the floor mounts and wall brackets for pilasters. (see fig.1)

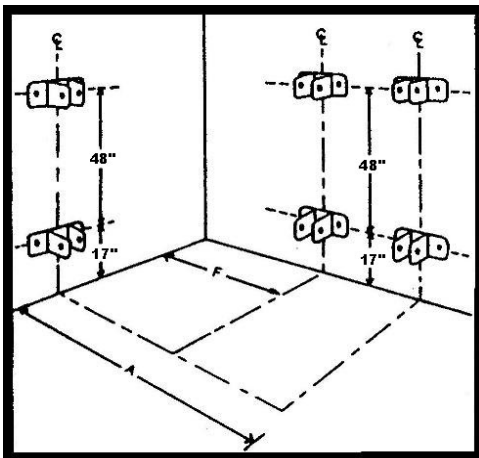

(fig.2)

Determine the finished overall width of the installation or centerline on panel(s). This measurement appears on your shop drawing. Mark the width and chalk line as Illustrated. (see fig.2)

Please Note: Double laminated panels require additional support of a third bracket centered between the top and bottom brackets.

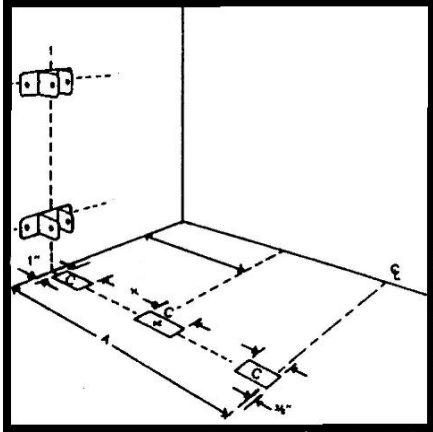

(fig.3)

For multiple unit installations determine the width of each individual compartment. (see fig. 3) Refer to these layout lines during installation of partition panels. Locate bottom panel bracket 17" above the floor, the upper bracket 48" above the bottom bracket. (where your bracket is placed) Locate anchors in mortar joints or grout lines whenever possible. On the back wall use 7/8" panel brackets (see fig.2). On the sidewalls use 1 1/4" plaster a brackets. Mark anchor positions using the brackets as templates. Drill 5/16" diameter holes, insert plastic anchors and mount all pilasters, and panel brackets into the wall with #14 X 1 1/4" Phillips screws. Distance between pilasters is determined by adding 3/8" (hardware clearance) to actual door sizes.

Starting at the existing sidewalls mark off the actual width of the individual pilasters along the depth line determined in step 1. Size and location of each pilaster appear on your shop drawings. (Allow 1/2" to 1" between side wall and first pilaster as an allowance for out of plumb wall, base moldings, and pilaster bracket thickness.) At the outside corner of the installation (in corner & alcove plans) locate outside edge of pilaster shoe 3/8" beyond layout line "A". End panel should mount flush with outside edge of pilasters. (see fig. 3)

Pilaster:

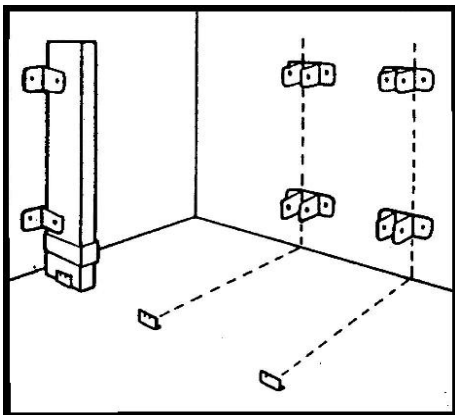

(Fig. 4)

Attach the anchor threaded rod (3/8" X 5") with washers, lock washers, and nuts on each anchor point. (2nuts, 2 flat washers, 2 lock washers per bolt) Align pilaster in position and mark the center of the bolts on the pilaster center. Drill 1/2" diameter hole into the concrete, 2 1/2" deep. Make alignment as necessary and for height. Slide the shoe cover up the pilaster approximately 12" and tape in place temporarily. Set the bolt into holes & adjust pilaster height. It should be possible to fill all anchors at one time with the epoxy mortar. To prevent the mixing tip used from hardening before completed(See fig.4)

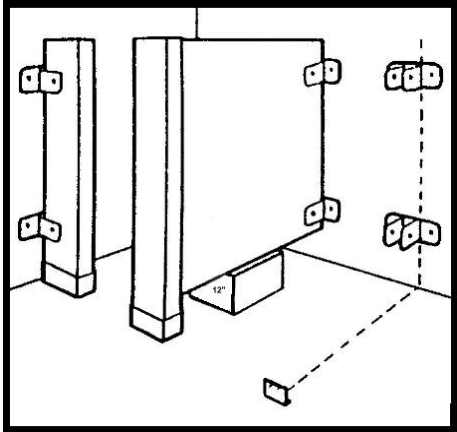

(fig. 5)

Install wall and floor mount pilaster(s) as supplied. Position the pilaster in the pilaster bracket. (Remember to slide the pilaster shoe in place) Plumb and level pilaster to appropriate height. (70" for un-braced and 80" for over head braced) Drill 1/4" holes through bracket holes and pilaster. Fasten with shoulder screws and barrel nut sets. (see fig.5)

Note: Wall to wall floor plans may be supplied with two wall mount only pilasters. (meaning: the pilasters will not mount to the floor.) Locate the panel (U-bracket) positions on remaining floor mounted pilaster and chalk line as illustrated. Mark center for first U-bracket 17" from the bottom of the pilaster, center second U-bracket 48" from the center of the first. Mark holes for drilling using the U-brackets as a template. Drill 5/16" starter holes into pilaster using a drill bit. (17/64 bit only through the Corian and 7/32 drill bit for wood). **DO NOT DRILL THROUGH THE PILASTER.** Fasten U-brackets to pilasters with #14 pan head wood screws.

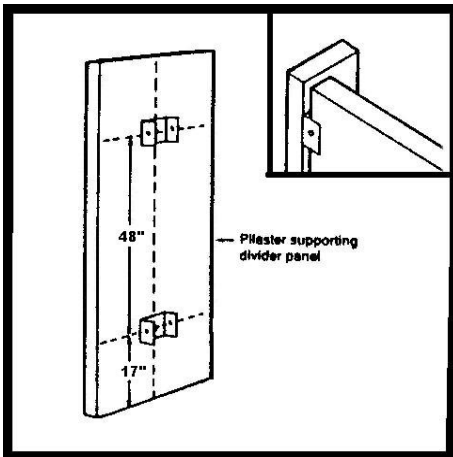

(fig. 6)

NOTE: For outside corner pilasters (corner and open alcove plans) mount U-brackets flush with edge of pilaster. The panel joint will be offset. (See top corner of fig. 6)

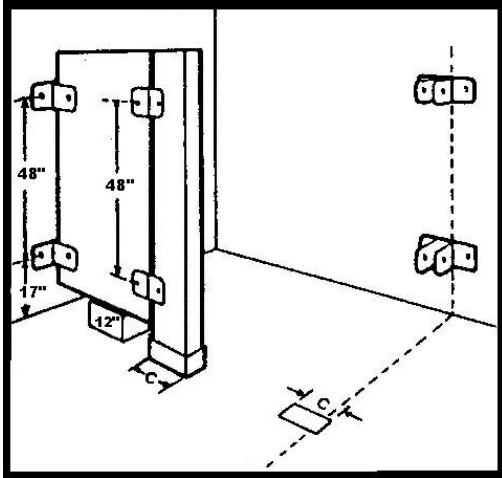

Set the remaining pilaster(s) in place and adjust leveling bolt to desired height. Drill 7/64" pilot holes and attach pilaster to mounting bracket using 1-#14 phillips head screw.

To secure panels to the wall and pilasters, set 12" support in place (see fig. 7). Position panel on support and between panel bracket ears. Place pilaster into shoes, and inset panel into U-brackets on the pilaster. Check for level height of pilasters across the installation. Plumb pilaster. Drill 1/4" holes through brackets and panel. Fasten panel to U-brackets and wall brackets using a shoulder screw and barrel nut set. Repeat for remaining pilasters and partition panels. Slide shoe covers into place covering pilaster mounts.

(fig. 7)

Fasten C-style hinge pin retainer in top cutout in door with #8 phillips/flat head screw (pre attached). Align hole in pilaster hinge bracket with the hole in the C-style hinge pin retainer. Insert 3/8" diameter steel pin. Applying a small amount of silicone adhesive to the serrated end of the hinge pin. This will prevent the pin from backing out and will allow the pin to be removed if needed.

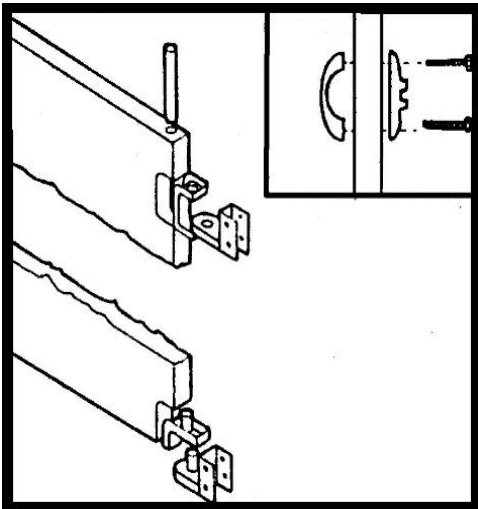

Fasten L-style hinge pin retainer to bottom cutout in door with #8 phillips/flat head screw (pre attached). Assemble socket type nylon bushing and bottom pilaster hinge bracket. Bushing must rotate on pre-assembled bearing to its lowest position. Align pilaster hinge bracket and nylon bushing with hole in L-style hinge retainer and press together until bushing is fully seated. (see fig. 8)

Mount handle (handles optional) & latch to the inside of the door in provided holes. Mount latch on door using oval machine head screws and unslotted barrel nuts. (top corner of fig.8)

NOTE: For **out swing door**, mount latch on inside of door while aligning handle on outside surface of door. Mount both components with 2 oval machine head screws.

(fig. 8)

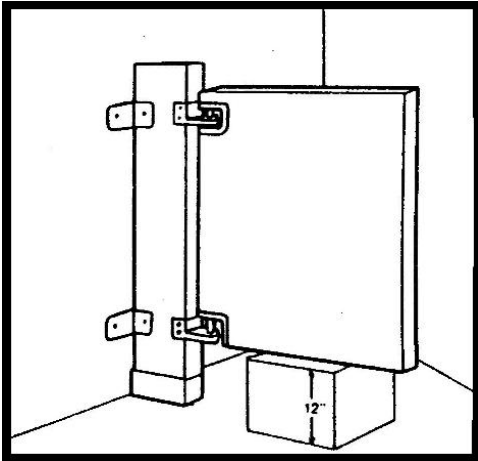

(fig. 9)

Place 12" high support in the position as illustrated. Put door on support and position pilaster hinge mount brackets around pilasters.

Beginning with the bottom hinge assembly as template, drill $\frac{1}{4}$ " holes through pilaster and mount with shoulder bolt and barrel nut set.

To properly position to top pilaster hinge mount bracket, slide the bracket on the steel hinge pin to within $\frac{1}{16}$ " of the top edge of C-style hinge pin retainer with door in closed position. Using the pilaster hinge mount bracket as template, drill $\frac{1}{4}$ " holes through pilaster and mount with shoulder bolt barrel nut set.

Note: The pre-set door opening nylon bushing may be re-set with a simple adjustment to conform to specific site requirements and to avoid excess slam force. After hanging the door, simply loosen the hex head nut on the underside of the bottom hinge assembly. With standard screw driver rotate the bushing assembly until the door automatically swings open to the desired position. Hold the bushing in position with your screwdriver and re-tighten the hex nut.

HEADRAIL

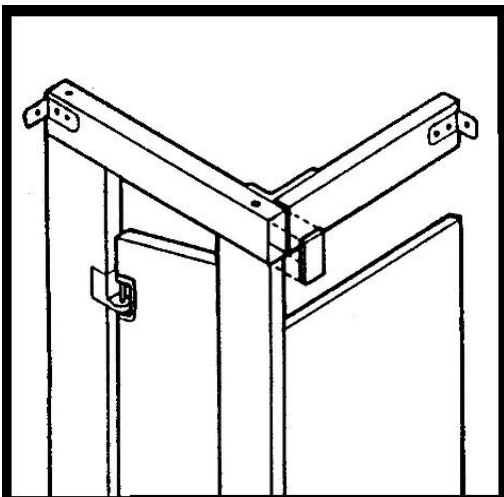

To mount overhead bracing, position overhead brace on top of pilaster. Mark and cut overhead bracing to fit flush at wall, and miter or butt joints at outside corners.

Reinforce wall joints and outside corner joints with headrail brackets. Using brackets as templates, mark and drill $\frac{3}{16}$ " diameter holes into overhead bracing and drill $\frac{5}{16}$ " diameter holes into walls. Insert plastic anchors into wall and fasten brackets to overhead with #14 phillips pan head sheet metal screws.

Dry fit all overhead bracing before bolting. When properly fit, add silicone to top of each pilaster. (you may wish to use hot glue for clamping until silicone dries.)

(fig. 10)

Important: DO NOT DRILL THROUGH THE FLANGE OF BRACING & SCREEN TO PILASTERS. BREAKAGE OF PILASTER IS VERY LIKELY TO OCCUR.

Note: Wall to wall and closed alcove units are supplied with overhead bracing across the front of the unit(s) only. Corner and open alcove units are supplied with overhead bracing across the front of the unit(s) and across the panel end.

Run a single bead of silicone chalk all the way around the base & top of the pilaster shoe when finished installing all partitions.

Installing the coat hook. There are predrilled holes and inserts in the doors. To insure that the coat hooks remain on the doors it is recommended that silicone adhesive is used as well as the screws that are provided.

WARNING:

DO NOT ATTACH ARTICLES WITH ANY TYPE OF SCREW DIRECTLY INTO THE SOLID SURFACE. THIS COULD CAUSE THE PART TO CRACK AND WILL VOID ALL WARRANTY WHAT SO EVER. ALL SCREWS MUST BE INSERTED INTO NYLON SLEEVES WITH CORRECT CLEARANCES IF REQUIRED